

GR / GM

Direct supply unit and mixing units for surface heating and cooling



INSTALLATION MANUAL



	Description	Pg.
	General	3
	Disposal	3
	General safety rules	4
	Safety warnings	5
	Installation warnings	5
1	PRODUCT DESCRIPTION	6
2	MANIFOLD DESCRIPTION (OPTIONAL)	10
3	INDICATIVE DIAGRAMS	12
4	INSTALLATION	14
5	FIRST START-UP	16
6	MAINTENANCE	17
7	TECHNICAL DATA	19

GENERAL

This manual is an integral and essential part of the product. Read the instructions and warnings carefully as they provide important information regarding safe installation, use and maintenance.

The technical notes and instructions contained in this document are intended for installers to help them perform correct installation in accordance with best practice.

The module is intended exclusively for the circulation of technical water in heating systems.

Use for purposes other than those specified is prohibited. The manufacturer is not considered responsible for any damage resulting from improper, incorrect or unreasonable use or failure to comply with the instructions provided in this manual.

Design, installation, maintenance and any other intervention must be carried out in compliance with the regulations in force and with the instructions provided by the manufacturer. Incorrect installation can cause damage to people, animals and property, for which the manufacturer is not responsible. The module is supplied in a cardboard package. After having removed the packaging, check the conditions of the device and make sure the supply is complete. Please, contact the supplier in case of non-compliance.

RDZ however reserves the right to modify or improve the product, the related technical data and the accompanying documentation at any time and without prior notice.

DISPOSAL



Based on the provisions of the following European Directives 2011/65/EU, 2012/19/EU and 2003/108/EC concerning the reduction of the use of hazardous substances in electrical and electronic equipment, as well as the disposal of waste.

The crossed bin symbol on equipment indicates that the product must be collected separately from other waste at the end of its useful life.

The user must therefore give the equipment to the appropriate collection centres for electronic and electro-technical waste at the end of its life, or return it to the retailer upon purchase of a new type of equivalent equipment, on a one-to-one basis. Suitable separated collection so that the unit no longer used can be sent off for environmentally compatible recycling, treatment and disposal helps avoid possible negative effects on the environment and on health and facilitates the recycling of the product's component materials.

Illegal disposal of the product by the user entails the application of the penalties provided for by current legislation.



GENERAL SAFETY RULES

Install the device on a solid wall that is not subject to vibrations.
Noise during operation.

Do not damage existing electric cables or pipes when drilling into the wall.

Electrocution due to contact with live conductors. Explosions, fires or poisoning due to gas leakage from damaged pipes. Damage to existing plants. Flooding due to water leakage from damaged pipes.

Make the electrical connections using suitable cross-section conductors.

Fire due to overheating caused by the passage of electric current in undersized cables.

Protect piping and connecting cables to avoid damaging them.

Electrocution due to contact with live conductors. Explosions, fires or poisoning due to gas leakage from damaged pipes. Flooding due to water leakage from damaged pipes.

Make sure that the installation environment and the systems to which the device must connect comply with the regulations in force.

Electrocution due to contact with incorrectly connected live conductors.

Damage to the device due to improper operating conditions.

Utilise manual tools and equipment suitable for use (in particular, make sure that the tool is not damaged and that the handle is intact and properly fixed), using them correctly, making sure they do not fall from a height, and storing them after use.

Personal injury due to the projection of splinters or fragments, dust inhalation, bumps, cuts, punctures, or abrasions.

Damage to the device or surrounding objects due to projecting splinters, impact or incisions.

Utilise electrical equipment suitable for use (in particular, make sure that the power cable and plug are intact and that the parts equipped with rotating or reciprocating motion are correctly fixed), using them correctly. Do not obstruct the passages with the power cable, make sure they do not fall from a height, and disconnect and store them after use.

Personal injury due to the projection of splinters or fragments, dust inhalation, bumps, cuts, punctures, abrasions, noise or vibrations. Damage to the device or surrounding objects due to projecting splinters, impact or incisions.

Make sure that the portable ladders are firmly resting and are appropriately resistant, that the steps are intact and not slippery, that they are not moved while someone is on them and that there is always someone supervising.

Personal injury due to falling from a height or shearing (double ladders).

Make sure that the platform ladders are firmly resting and are appropriately resistant, that the steps are intact and not slippery, that they have handrails along the ramp and railing on the landing.

Personal injury due to falls from a height.

During works carried out at a height (generally with a difference in height of more than two metres), make sure that perimeter railings in the work area or individual harnesses to prevent falls are used, that the space travelled during falls is free from dangerous obstacles and that any impact is mitigated

by semi-rigid or deformable stop surfaces.

Personal injury due to falls from a height.

Make sure that the workplace has adequate sanitary conditions with regard to lighting, ventilation and soundness.

Personal injury due to impact, tripping, etc.

Protect the device and areas near the workplace with adequate material.

Damage to the device or surrounding objects due to projecting splinters, impact or incisions.

Handle the device with the necessary protections and with due caution.

Damage to the device or surrounding objects due to collision, impact, incisions or crushing.

Wear personal protective clothing and equipment during processing.

Personal injury due to electrocution, the projection of splinters or fragments, dust inhalation, impact, cuts, punctures, abrasions, noise or vibrations.

Organise the dislocation of material and equipment in order to make handling easier and safer, avoiding piles that may be subject to sagging or collapse.

Damage to the device or surrounding objects due to collision, impact, incisions or crushing.

Operations inside the device must be carried out with the necessary caution to avoid sudden contact with sharp parts.

Personal injury due to cuts, punctures or abrasion.

Restore all safety and control functions affected by intervention on the device and verify its functionality before restarting.

Explosions, fires or poisoning due to gas leakage or incorrect smoke exhaust.

Damage or blocking of the device due to out of control operations.

Empty components that may contain hot water, activating any vents before handling them.

Personal injury due to burns.

Perform limescale descaling of components in accordance with the information provided on the safety data sheet of the product used, ventilating the environment, wearing protective clothing, avoiding mixing different products, and protecting the device and surrounding objects.

Personal injury due to skin or eye contact with acidic substances, inhalation or ingestion of harmful chemical agents.

Damage to the device or surrounding objects due to corrosion from acidic substances.

In the event of a burning smell or smoke coming out of the device, disconnect the power supply, open windows and notify the technician.

Personal injury due to burns, inhalation of fumes, poisoning.



SAFETY WARNINGS

Failure to comply with warnings entails risks of damage, including serious damage, to objects, plants and animals and even fatal injuries to people under certain circumstances.

When assembling or maintaining the device, utilise manual tools and equipment suitable for use, making sure in particular that handles are intact and properly secured.

When using electrical equipment, make sure that it is suitable for use, in particular make sure that the power cable is intact and that the plug is properly secured.

Do not interfere with the passage of cables when using electrical equipment.

Make sure that the portable ladders used for device installation are firmly resting on the ground, that they are appropriately resistant and that the steps are intact and not slippery.

Wear personal protective clothing and equipment during processing.

Organise the dislocation of material and equipment in order to make their handling easier and safer, avoiding piles that may be subject to sagging or collapse.

Empty components that may contain hot water, activating any device vents before handling them.

Perform limescale descaling on the device in accordance with the information provided on the safety data sheet of the product used, ventilating the environment, wearing protective clothing, avoiding mixing different products, and protecting the device and surrounding objects.

In the event of a burning smell or smoke coming out of the device, disconnect the power supply and open windows.

INSTALLATION WARNINGS

The device must only be installed by qualified personnel who meet the requirements of the country where the product is installed.

Make sure that the installation environment and the system to which the device must connect complies with the regulations in force.

Make sure that the workplace has adequate sanitary conditions with regard to lighting, ventilation and soundness.

Install the module on a solid wall that is not subject to vibrations. Do not damage existing pipes when drilling into the wall.

Make sure that the fastening system is suitable for use when connecting directly to a primary storage.

Make the electrical connections using suitable cross-section conductors.

Handle the device with the necessary protections and with due caution.

Empty parts that may contain hot water, activating any vents before handling them.

When handling the device, protect piping and connecting cables to avoid damaging them.

Restore all safety and control functions affected by intervention on the device and verify functioning before restarting.

During assembly, make sure that the open ends of ducts are protected against the penetration of dirt.

The module is live. Disconnect the power supply before carrying out any maintenance on electrical components.

Versions

This manual refers to products supplied in their standard configuration. However, versions may exist where some parts or features are different from those described. Where features are not perfectly consistent with the information provided in this manual, please pay special attention to the common safety regulations for the use of machinery or products containing live or high temperature parts. RDZ however reserves the right to modify or improve the product, the related technical data and the accompanying documentation at any time and without notice.



1 PRODUCT DESCRIPTION

CONNECTION GROUP GR 25

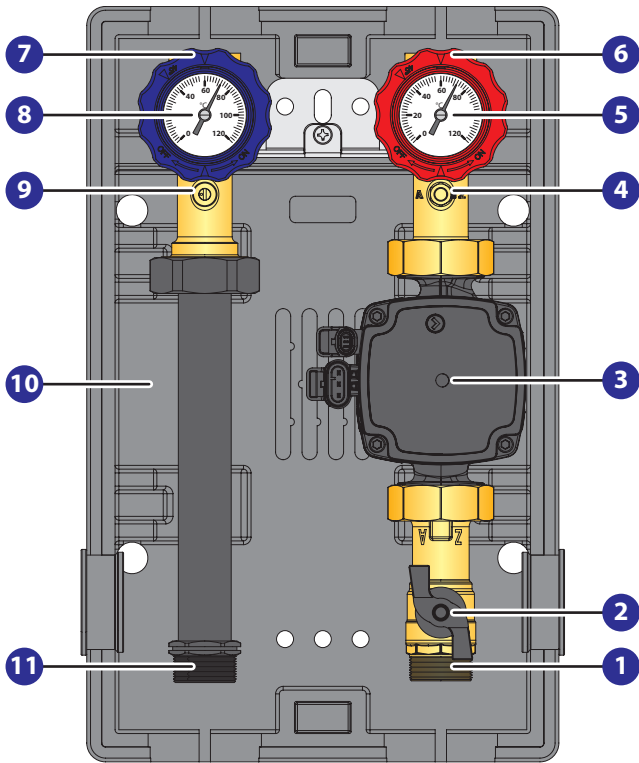

Num	Description
1	Water inlet from central heating plant M 1"
2	Shut-off ball valve
3	Circulator
4	Probe bulb/safety thermostat
5	Delivery thermometer with ball valve
6	System delivery F 1"
7	System return F 1"
8	Return thermometer with ball valve and check valve
9	Device for forcing always open check valve
10	PPE insulating shell
11	Return to central heating plant M 1"

CONNECTION GROUP GR 32

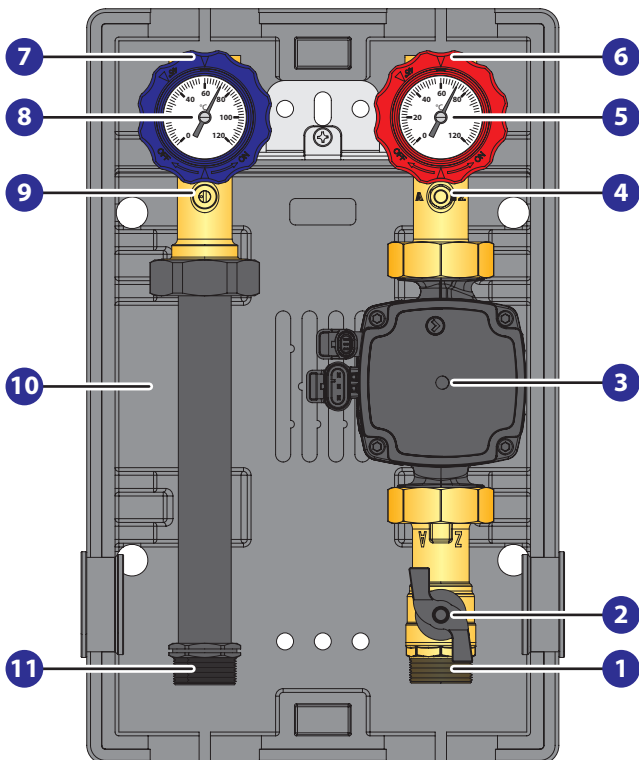

Num	Description
1	Water inlet from central heating plant M 1 1/4"
2	Shut-off ball valve
3	Circulator
4	Probe bulb/safety thermostat
5	Delivery thermometer with ball valve
6	System delivery F 1 1/4"
7	System return F 1 1/4"
8	Return thermometer with ball valve and check valve
9	Device for forcing always open check valve
10	PPE insulating shell
11	Return to central heating plant M 1 1/4"

3-POINT MIXING GROUP GM DN 25

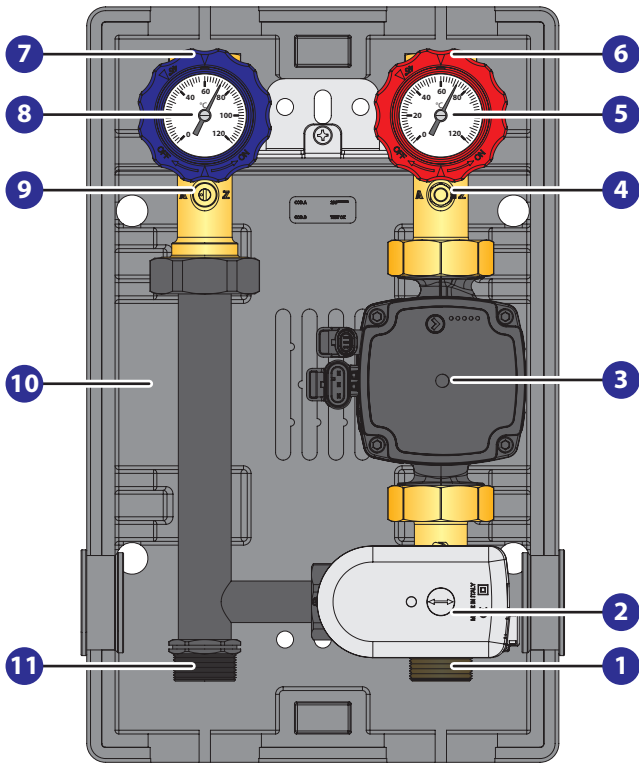

Num	Description
1	Water inlet from central heating plant M 1"
2	Mixer valve with 3-point servomotor 230 V
3	Circulator
4	Probe bulb/safety thermostat
5	Delivery thermometer with ball valve
6	System delivery F 1"
7	System return F 1"
8	Return thermometer with ball valve and check valve
9	Device for forcing always open check valve
10	PPE insulating shell
11	Return to central heating plant M 1"

MIXING GROUP GM PF DN 25

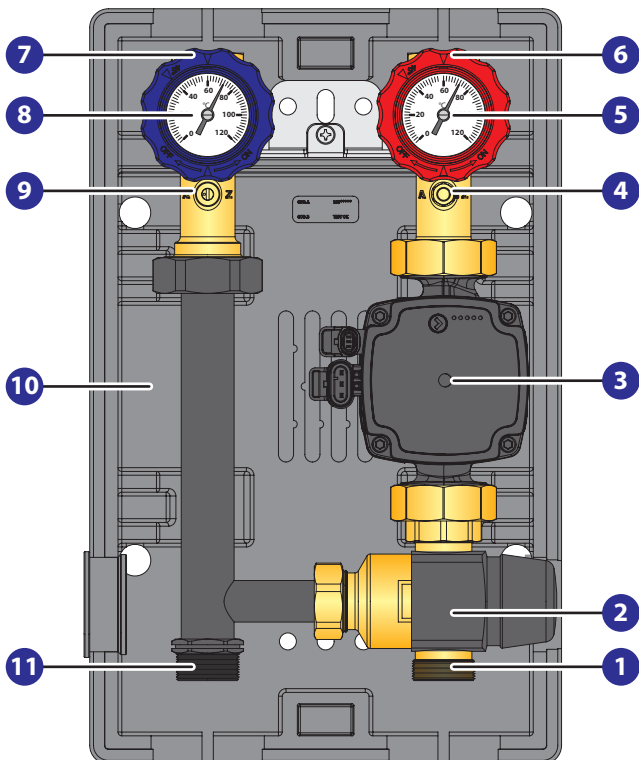

Num	Description
1	Water inlet from central heating plant M 1"
2	Fixed point mixer valve
3	Circulator
4	Probe bulb/safety thermostat
5	Delivery thermometer with ball valve
6	System delivery F 1"
7	System return F 1"
8	Return thermometer with ball valve and check valve
9	Device for forcing always open check valve
10	PPE insulating shell
11	Return to central heating plant M 1"

MIXING GROUP GM PF DN 32

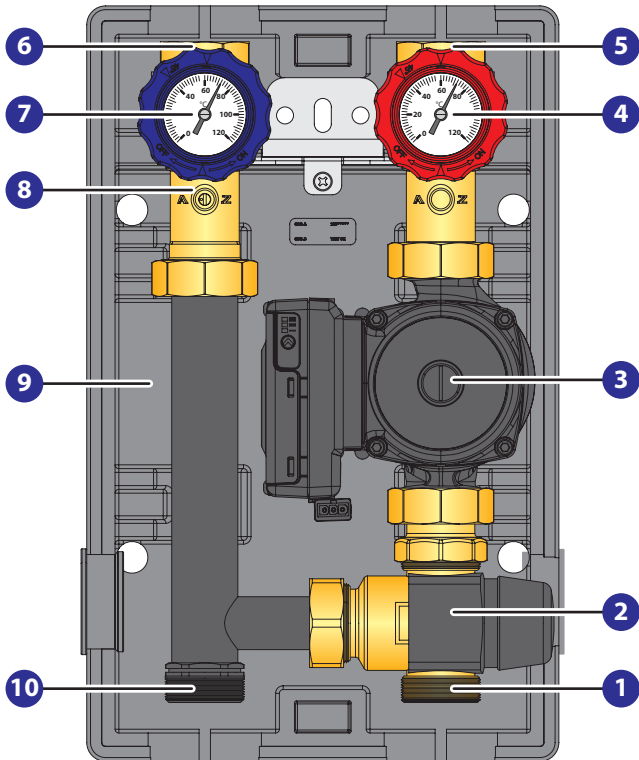

Num	Description
1	Water inlet from central heating plant M 1 ¼"
2	Fixed point mixer valve
3	Circulator
4	Delivery thermometer with ball valve
5	System delivery F 1 ¼"
6	System return F 1 ¼"
7	Return thermometer with ball valve and check valve
8	Device for forcing always open check valve
9	PPE insulating shell
10	Return to central heating plant M 1 ¼"

MIXING GROUP GM PF-CF DN 25

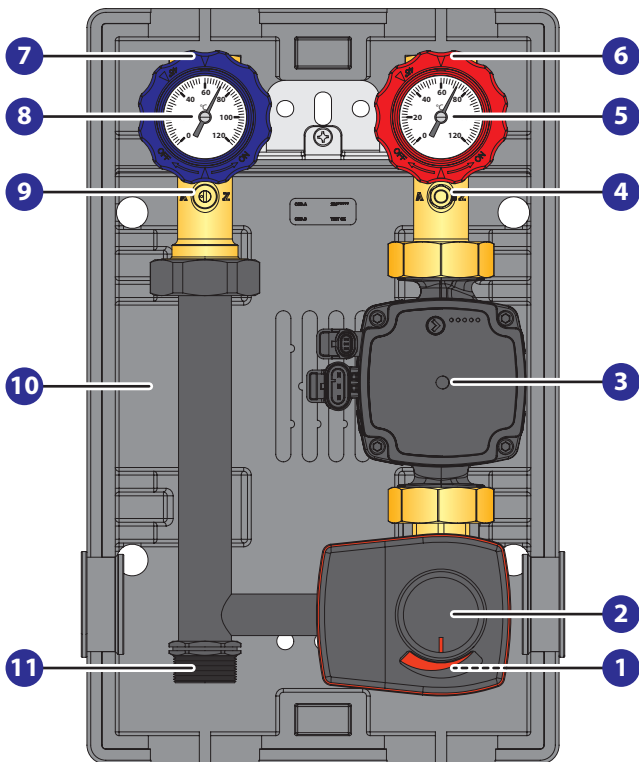

Num	Description
1	Water inlet from central heating plant M 1"
2	Mixer with fixed point electronic Hot/Cold servomotor
3	Circulator
4	Probe bulb/safety thermostat
5	Delivery thermometer with ball valve
6	System delivery F 1"
7	System return F 1"
8	Return thermometer with ball valve and check valve
9	Device for forcing always open check valve
10	PPE insulating shell
11	Return to central heating plant M 1"

MIXING GROUP GM PF-CF DN 32

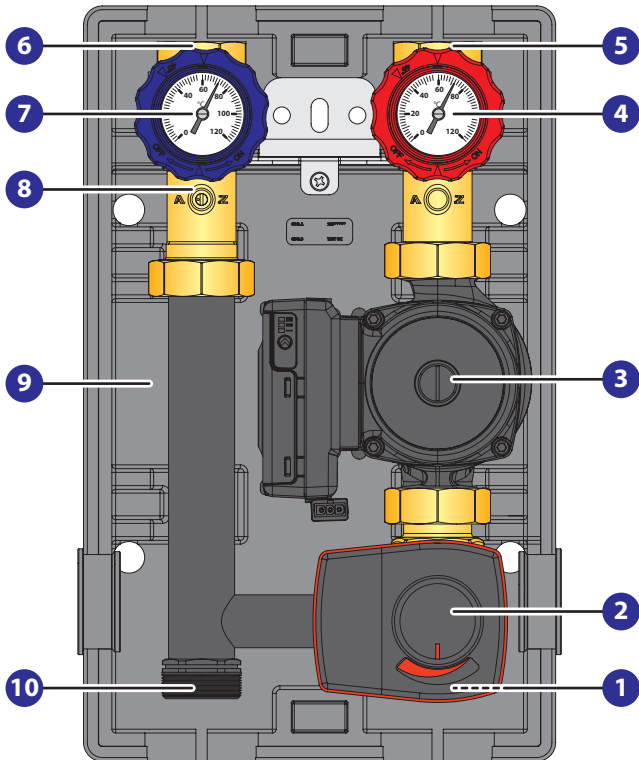

Num	Description
1	Water inlet from central heating plant M 1 ¼"
2	Mixer with fixed point electronic Hot/Cold servomotor
3	Circulator
4	Delivery thermometer with ball valve
5	System delivery F 1 ¼"
6	System return F 1 ¼"
7	Return thermometer with ball valve and check valve
8	Device for forcing always open check valve
9	PPE insulating shell
10	Return to central heating plant M 1 ¼"

MIXING GROUP GM VJ DN 25

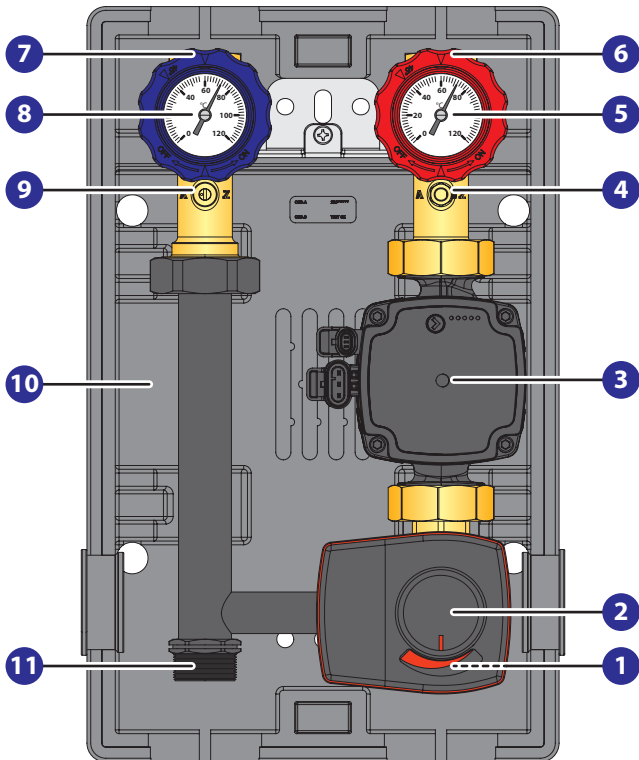

Num	Description
1	Water inlet from central heating plant M 1"
2	Mixer with electronic 24V servomotor with 0-10 V signal
3	Circulator
4	Probe bulb/safety thermostat
5	Delivery thermometer with ball valve
6	System delivery F 1"
7	System return F 1"
8	Return thermometer with ball valve and check valve
9	Device for forcing always open check valve
10	PPE insulating shell
11	Return to central heating plant M 1"



MIXING GROUP GM VJ DN 32

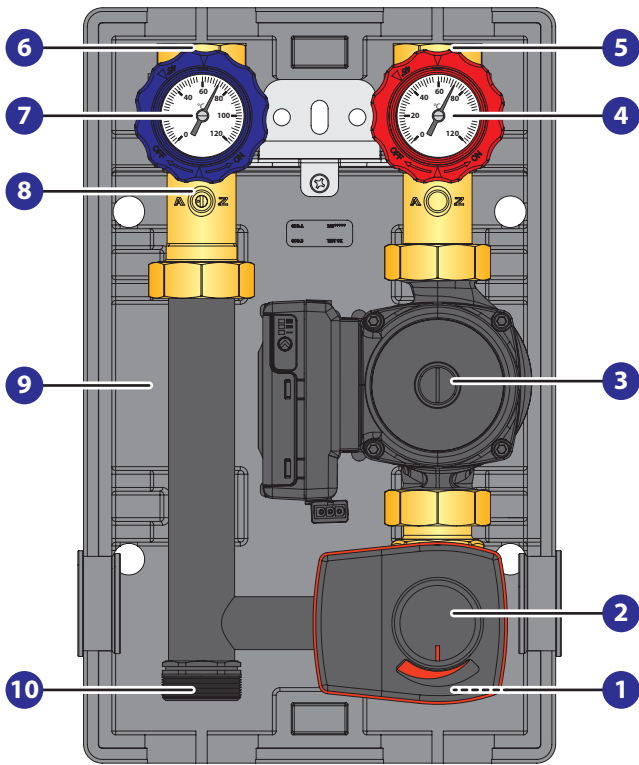

Num	Description
1	Water inlet from central heating plant M 1 ¼"
2	Mixer with electronic 24V servomotor with 0-10 V signal
3	Circulator
4	Delivery thermometer with ball valve
5	System delivery F 1 ¼"
6	System return F 1 ¼"
7	Return thermometer with ball valve and check valve
8	Device for forcing always open check valve
9	PPE insulating shell
10	Return to central heating plant M 1 ¼"

2 MANIFOLD DESCRIPTION (OPTIONAL)

MANIFOLDS

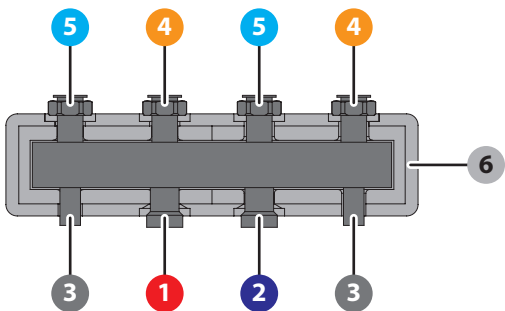

Num	Description
1	Water inlet from central heating plant M 1 ½"
2	Water outlet toward central heating plant M 1 ½"
3	Wall mounting connections
4	System delivery F 1 ½"
5	System return F 1 ½"
6	Insulating shell



Caution: the inlets and outlets on the central heating side on 3z manifolds must be inverted with respect to the other 2 models, as shown in the drawing to the side.

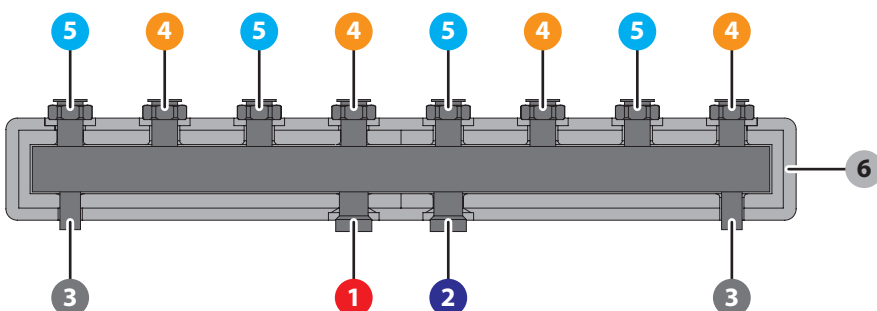
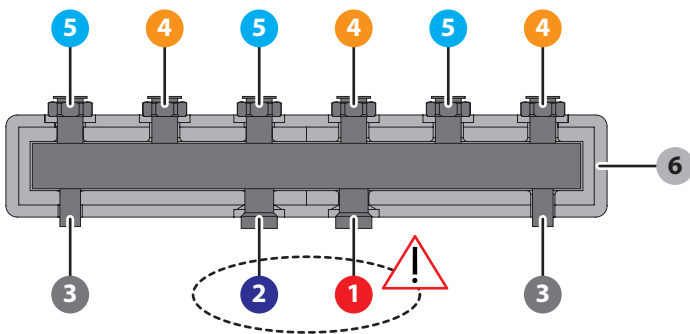



MANIFOLDS WITH SEPARATOR

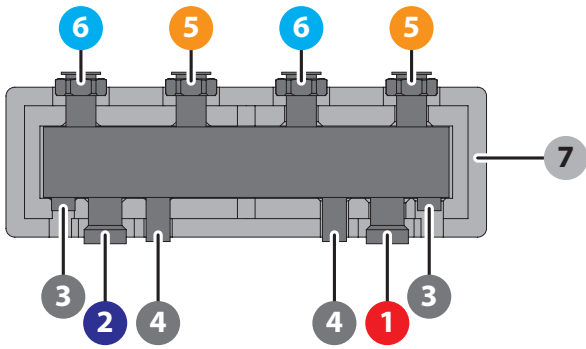

Num	Description
1	Water inlet from central heating plant M 1 1/2"
2	Water outlet toward central heating plant M 1 1/2"
3	Connections for installation of sensors and filling/draining tap F 1/2"
4	Wall mounting connections
5	System delivery F 1 1/2"
6	System return F 1 1/2"
7	Insulating shell

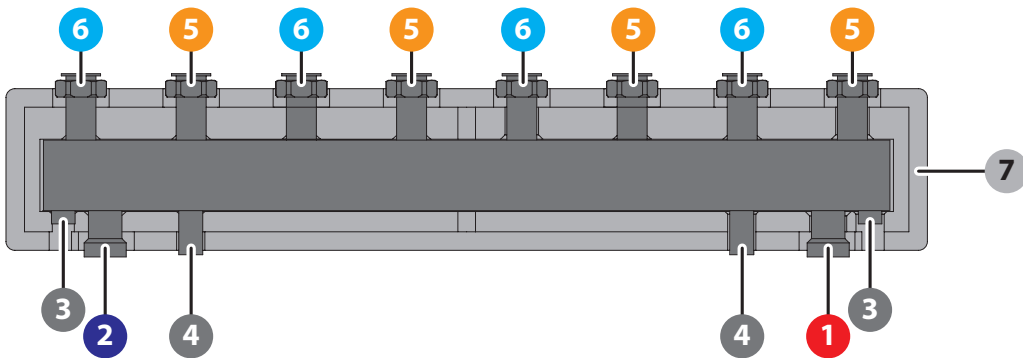
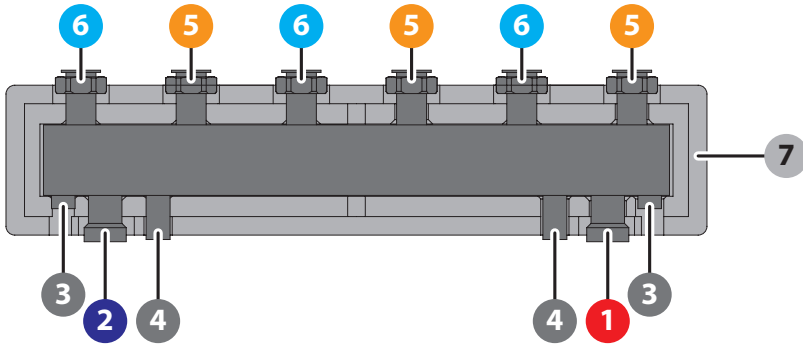



3 ROUGH DIAGRAMS

ROUGH DIAGRAM WITH MANIFOLDS

KEY TO SYMBOL	
	3-way valve
	Storage Tank

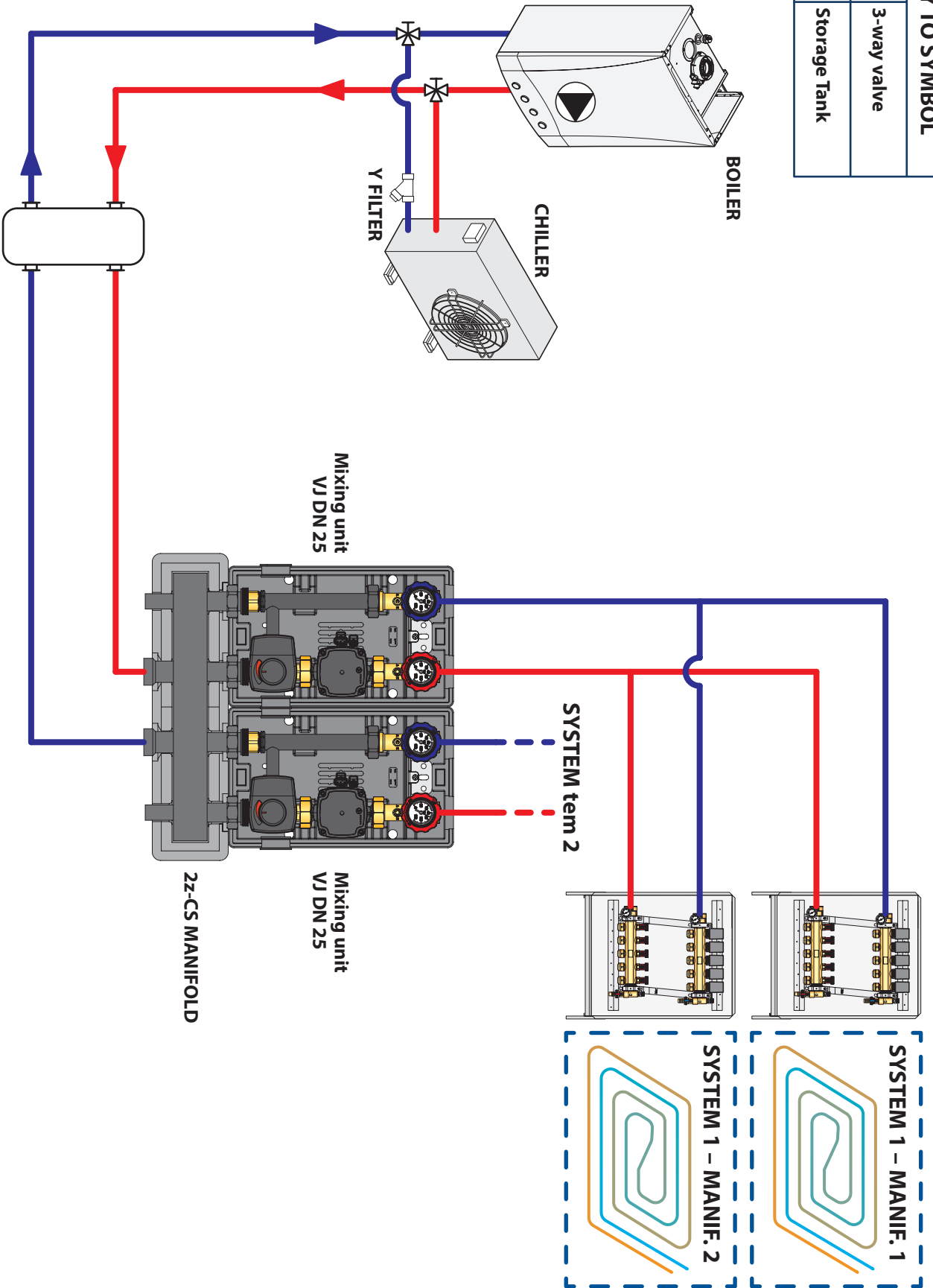

Installation example:
 2 heating and cooling systems with mixing valve and 2z-CS manifold supplying water from the storage tank.



ROUGH DIAGRAM WITH SEPARATORS

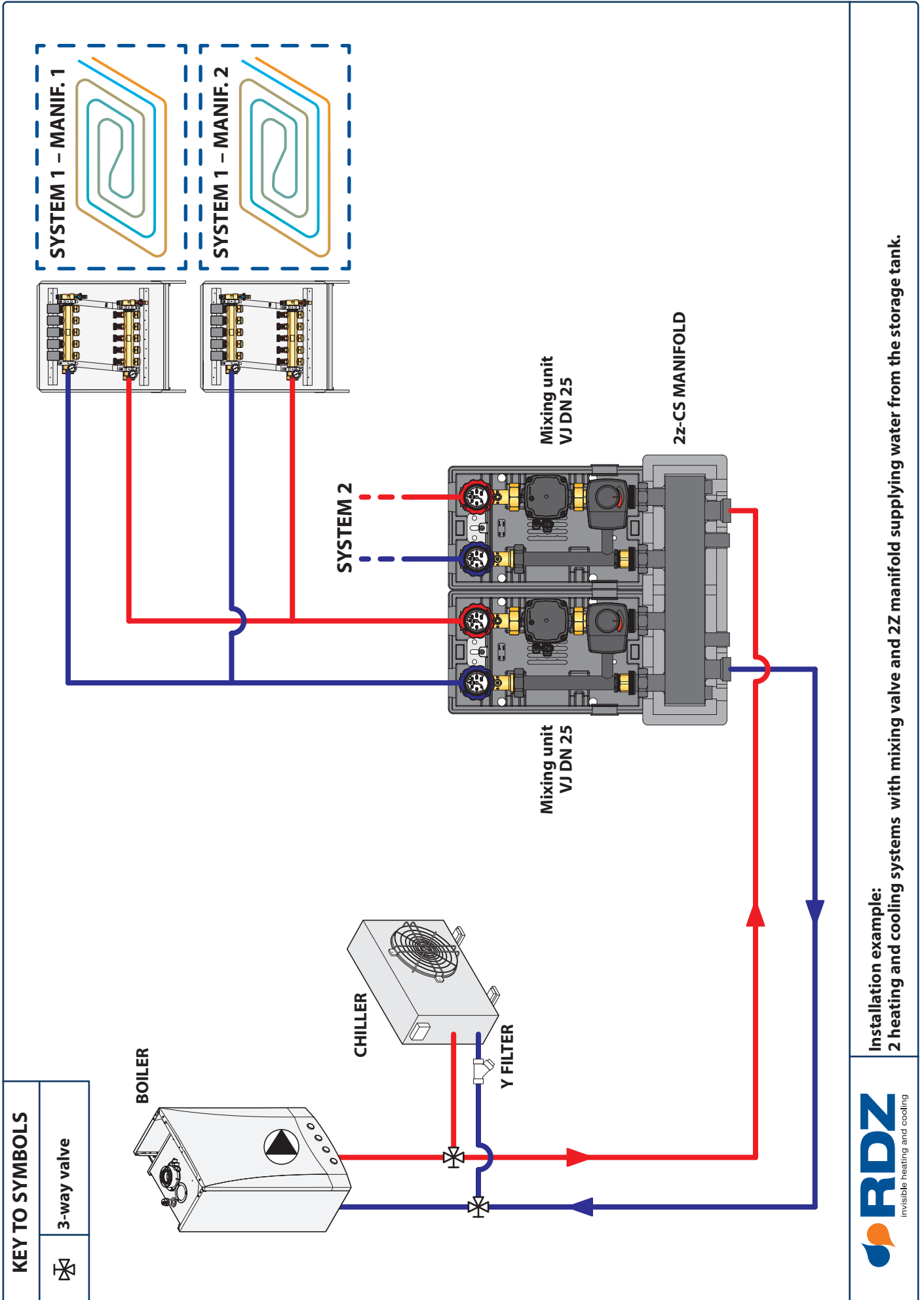

Installation example:
2 heating and cooling systems with mixing valve and 2z manifold supplying water from the storage tank.





4 INSTALLATION

WARNINGS

In order not to jeopardise regular operation of the module, the installation site must comply with the operating limit temperature value and be protected from atmospheric agents. The module has been designed to be mounted on a wall or directly on a storage tank (where fitted) and therefore it cannot be installed on a base or on the floor. When creating a technical compartment, comply with the minimum distances to ensure accessibility to the parts of the module.

Verify during transport and handling that all module components remain intact and have not been damaged due to impact.

Do not proceed with installation in the event of any obvious damage to the product.

CAUTION

Do not damage existing electric cables or pipes when drilling into the wall.

SINGLE WALL INSTALLATION

After having identified a suitable wall, mark and drill the wall, inserting a dowel suitable for the weight of the module and the shape of the wall itself.

Position the module and secure it to the wall with the supplied screw.

CAUTION

Check that the dowels supplied are suitable for the type of wall where the module will be secured. If they are not, replace them with an appropriate model.

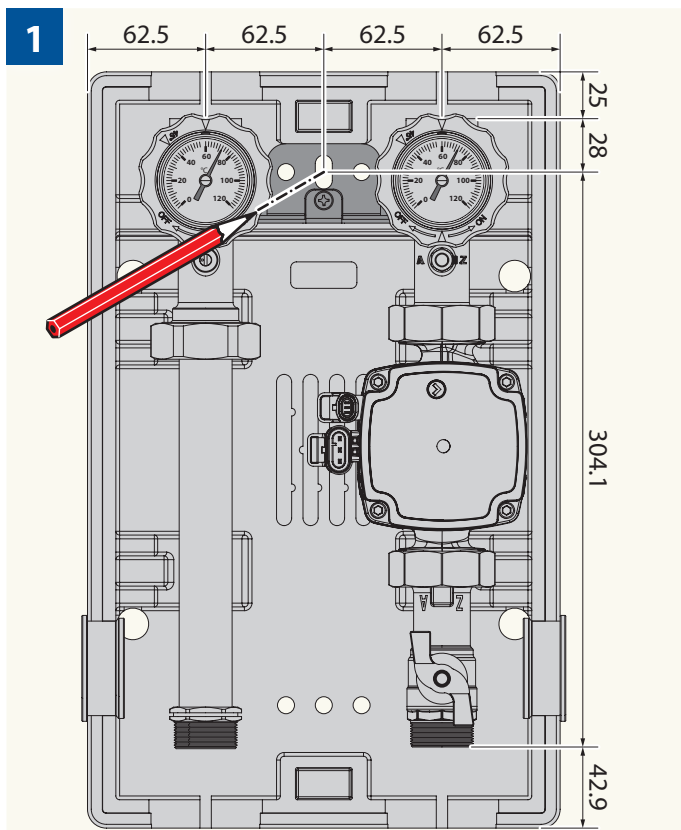

2

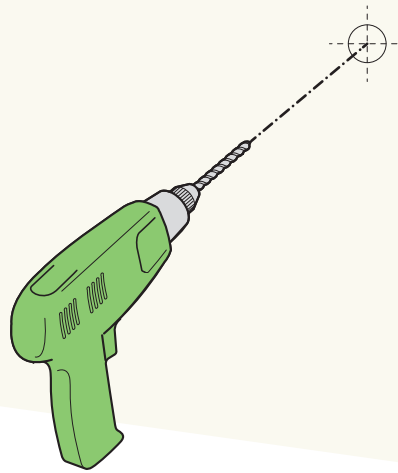

3

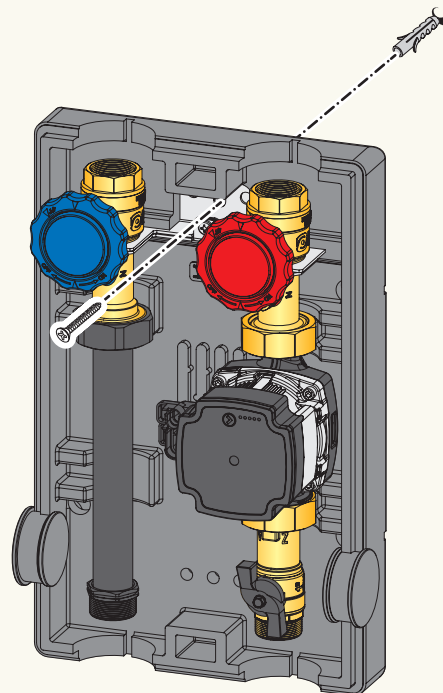



MULTIPLE INSTALLATION ON A WALL MANIFOLD

After having identified a suitable wall, mark and drill the wall, inserting dowels suitable for the weight of the hydraulic manifold.

When choosing the wall on which to place the hydraulic manifold, consider the dimensions of the manifold itself and of all the connected hydraulic modules.

When assessing the suitability of the fixing dowels, consider the structural characteristics of the wall, the weight of the hydraulic manifold, the weight of all the hydraulic modules and the weight of the water contained within the hydraulic parts.

Fix the manifold support brackets to the wall and position the manifold. Position the circulation units, connecting them to the hydraulic manifold.

Use adapters supplied by the device manufacturer to connect the hydraulic modules to the manifold.

Adapters with different characteristics are also available. See the catalogue to choose the most suitable version.

HYDRAULIC CONNECTION

The module must be connected to a system after being sized according to its performance and characteristics.

Before connecting it:

- Wash the pipes thoroughly to remove threading, welding or dirt residues that may compromise correct operation.
- Check that the circuit pressure does not exceed the design value.
- Check that the generator delivery temperature is within the design limits.
- Check that all the safety and functional devices are present on the system to ensure correct functioning of the module and the system.

Connect each single module to the hydraulic manifold, taking care to check and comply with the delivery and return positions. Be sure to properly tighten all connecting nuts to avoid hydraulic leaks.

Use gaskets suitable for contact with the liquid placed inside the heating circuit.

The module must include M connections on the generator side (hydraulic manifold) and F on the heating system. See the technical data table for measurements. If different connections are needed, you can use adapters supplied directly by the device manufacturer.

The manufacturer is not liable for malfunctions if the adapters are not suitable for use.

CAUTION

If one or more modules are installed for the management of mixed zones, it is mandatory to insert a safety thermostat downstream of the module that acts in case of problems or temperature drifts that can damage to the system.

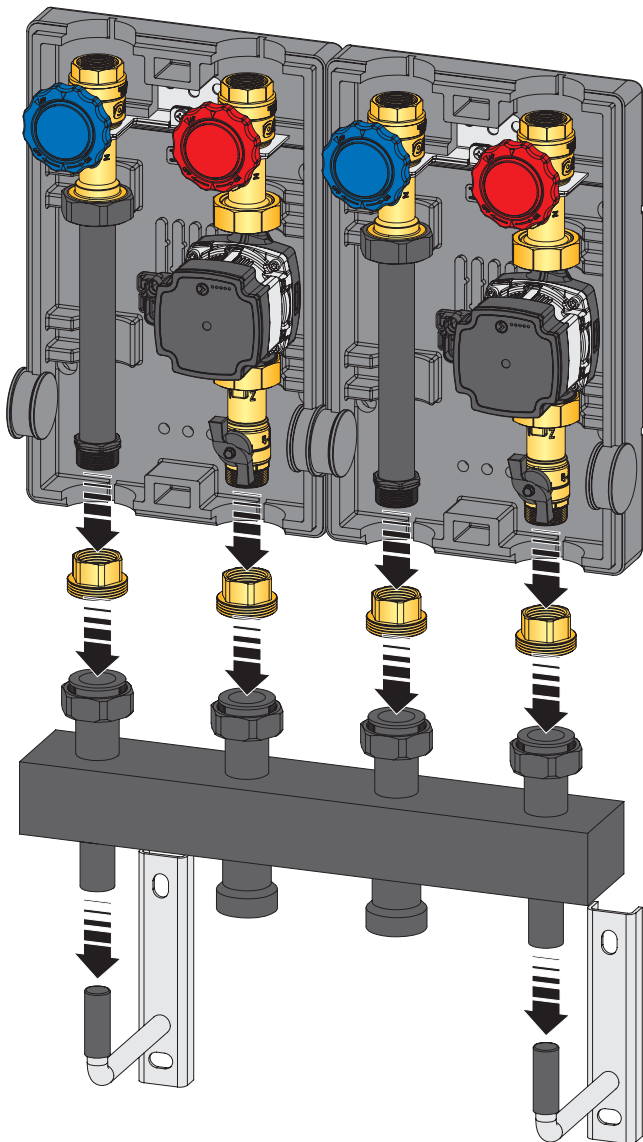



5 FIRST START-UP

WARNINGS

Before any interventions, disconnect the power supply via the external switch, since the module is powered. To guarantee the safety and correct operation of the module, commissioning must be carried out by a qualified technician who meets the legal requirements.

WASHING

All assembly, disassembly, installation and maintenance operations that may cause water leakage must be carried out by specialised technical personnel and with the power supply disconnected. Thoroughly clean the entire system to prevent assembly work residue from damaging the functional components of the module.

Check the tightening of all components on both the module and the connected circuits. It is important to check the seals before filling so as to avoid sprays or leaks that can be potentially dangerous for the electrical parts.

Open the shut-off taps on the module and begin filling the circuit according to system designer instructions.

Check that all connections are tight during filling. Stop the washing cycle when you are certain that the whole system has been properly washed.

FILLING AND VENTING

Fill the buffer tank (if present) and the whole circuit with water or correct liquid according to the design indications of the system and within the limits of the characteristics of the components used.

It is advisable to open the vents along the circuit when filling the system. Provide a deaeration cycle.

Check that the working pressure is correct at the end of the cycle. If the pressure is not sufficient, adjust the value by repeating the procedure described above.

The return valve on the module can be forcibly opened to facilitate filling and venting operations.

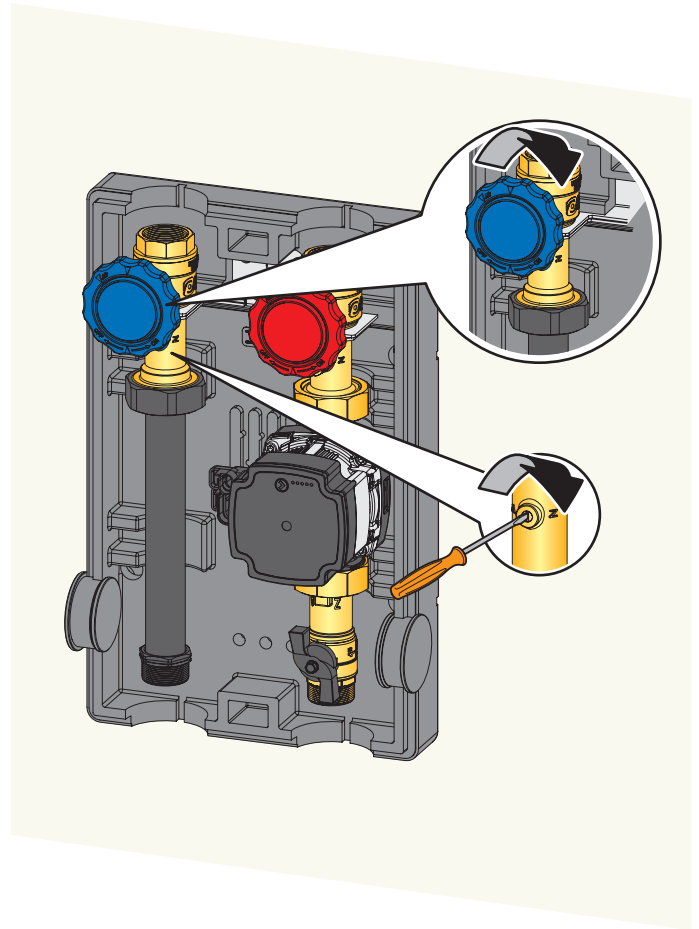

SETTINGS

Refer to the user manual of the system control and management unit for electrical connection, displays and setting of the system parameters.



6 MAINTENANCE

WARNINGS

Failure to comply with the warnings may result in damage, including serious damage under certain circumstances, for objects, plants and animals.

When maintaining the device, utilise manual tools and equipment suitable for use, making sure in particular that handles are intact and properly secured.

When using electrical equipment, make sure that it is suitable for use, in particular make sure that the power cable is intact and that the plug is properly secured.

Do not interfere with the passage of cables when using electrical equipment.

Perform system and module cleaning in accordance with the information provided on the safety data sheet of the product used, ventilating the environment, wearing protective clothing, avoiding mixing different products, and protecting the device and surrounding objects.

Before any interventions, disconnect the power supply via the external switch, since the module is continuously powered. To guarantee the safety and correct operation of the module, commissioning must be carried out by a qualified technician who meets the legal requirements.

PERIODIC MAINTENANCE

A precautionary check must be carried out once a year on the entire heating system, including the module.

It is important to check:

- All threaded or welded seals on the system
- For the presence of obvious air bubbles
- The mechanical conditions of the module components and of the safety elements on the system.

REPLACING THE CIRCULATOR

Caution

Before any interventions, disconnect the power supply via the external switch, since the module is powered.

There may be some hot water inside the module, which means risk of burns!

If the circulator needs to be replaced, close the system tap on the module and any tap upstream of the circulator itself. Disconnect the power cable.

Unscrew the nuts and replace the circulator. Even if there are no obvious signs of wear, it is advisable to replace the seals and check the conditions of the power cable.

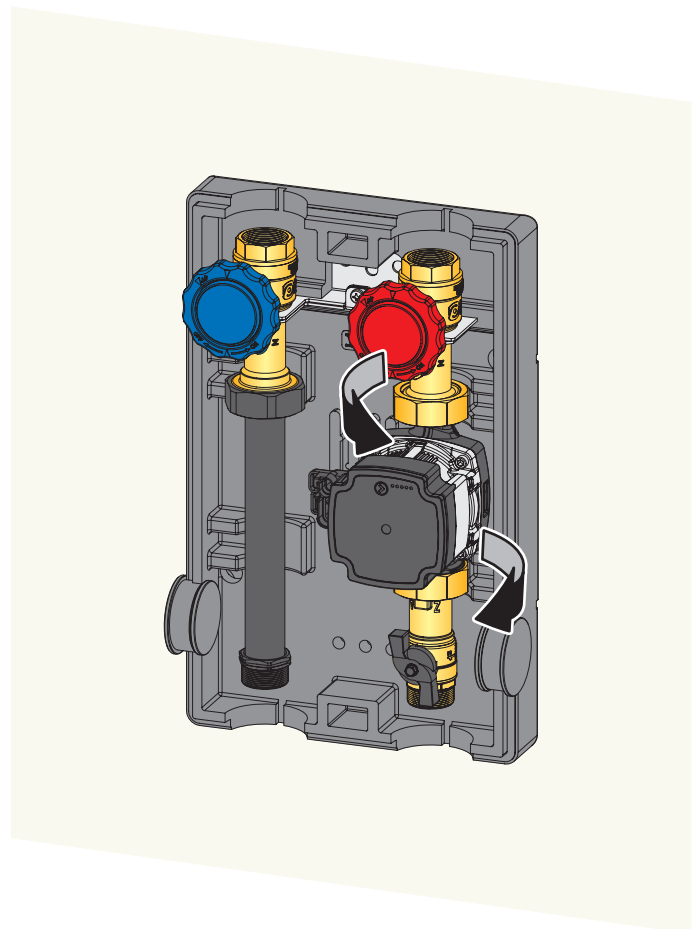



REPLACING THE MIXER VALVE (IF PRESENT)

If the mixer valve needs to be replaced, close the system tap on the module and any tap upstream of the manifold itself. Unscrew the nuts and replace the valve. Even if there are no obvious signs of wear, it is advisable to replace the seals. Pay attention to the following points when replacing module components:

- There may be hot water inside the module even after emptying: this means risk of burns.
- Parts to be subject to maintenance may be hot and heavy, and they shall be therefore handled with care.
- Seal gaskets should be replaced when components are dismantled.
- Replace worn components only using original spare parts supplied by the device manufacturer.
- Dispose of worn materials in accordance with the regulations in force in the country where the device is installed.

CHECK VALVE

A check valve is installed inside the module, on the return branch, whose purpose is to prevent eddy circulations inside the systems, especially when these are connected to hydraulic manifolds on which multiple circulators operate. This can be forcibly opened as shown in the images below.

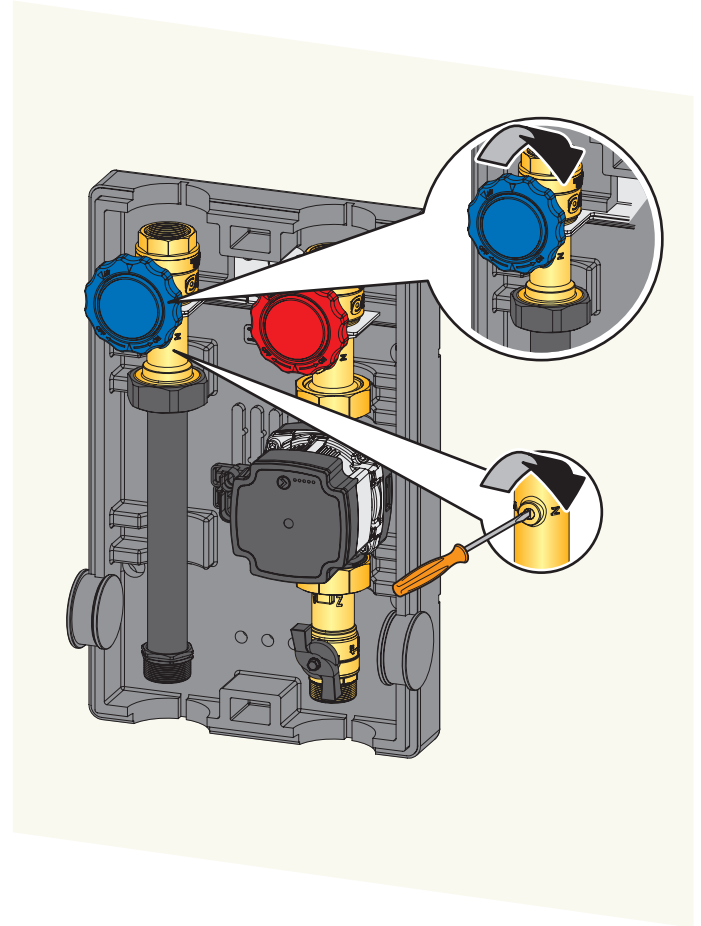



7 TECHNICAL DATA

			GR		GM PF		GM VJ / PF CF	
			DN 25	DN 32	DN 25	DN 32	DN 25	DN 32
Hydraulic circuit	Max Flow Rate	L/h	2000	4000	1500	2200	2000	4000
	Mixer Kvs		/	/	4.5	4.8	13	17
	Max Temperature	°C	95					
	Max Pressure	Bar	8					
	Liquid		Water / Water + glycol max 30%					
Electrical characteristics	Power supply voltage		230 V – 50 Hz					
	Max electrical absorption	W	63	151	63	151	63	151
Mechanical characteristics	Shut-off valves		DN 25	DN 32	DN 25	DN 32	DN 25	DN 32
	Generator side connections	Inch	1"	1 ¼"	1"	1 ¼"	1"	1 ¼"
	System side connections	Inch	1"	1 ¼"	1"	1 ¼"	1"	1 ¼"
	Distance between connections	mm	125					
	Dimensions	mm	400x250x210					
	Weight	Kg	5.0	5.3	5.3	5.3	5.4	5.7

HYDRAULIC OUTPUT

GR DN 25

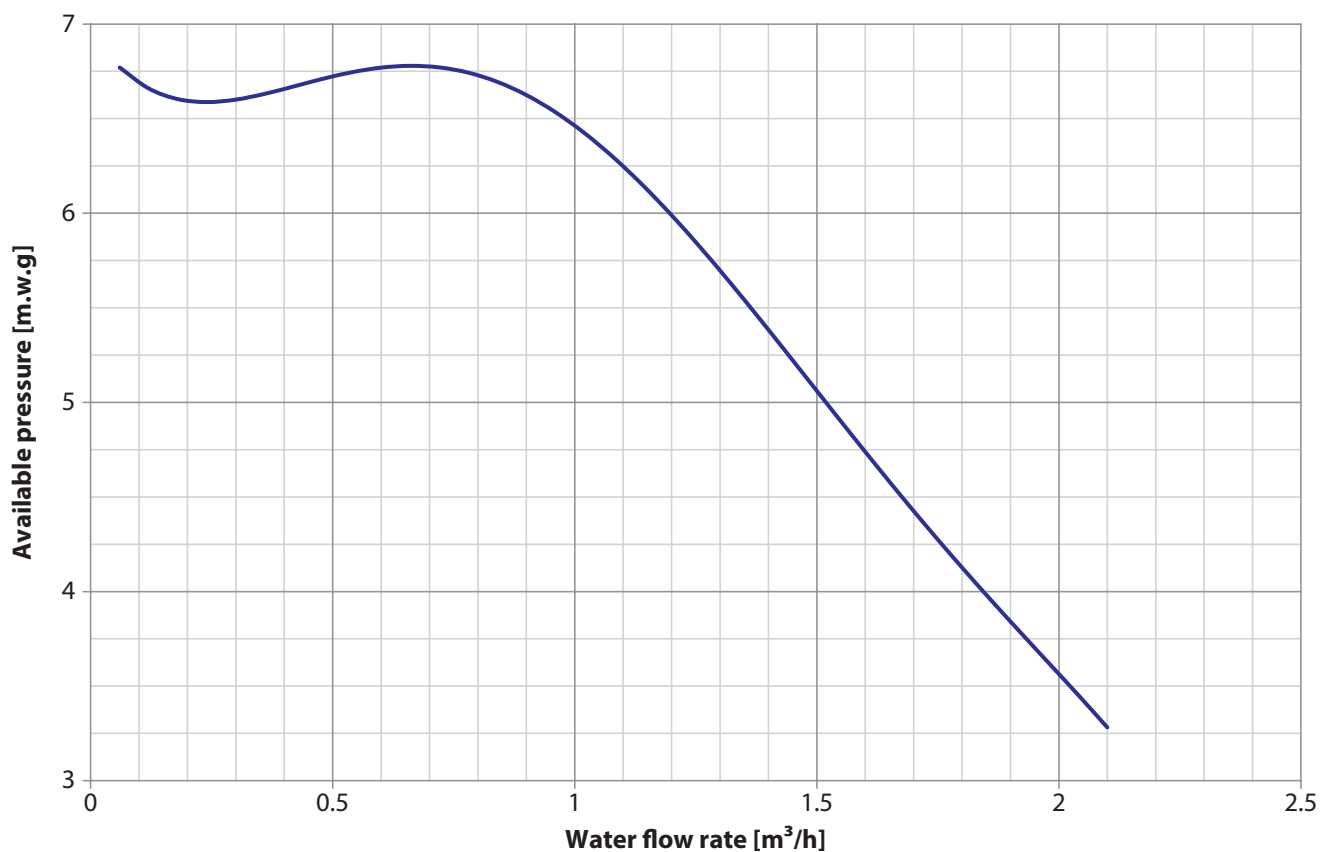



GR DN 32

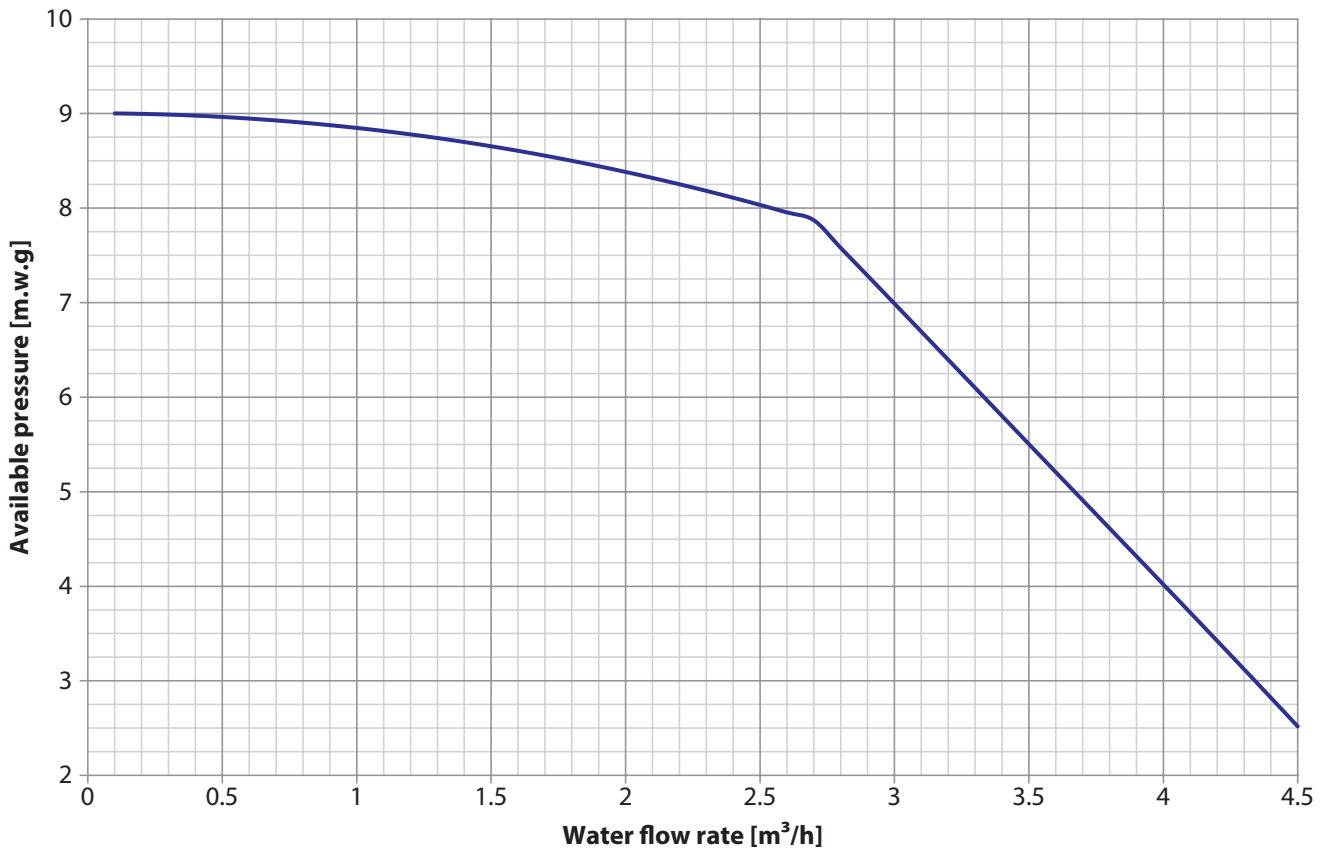

GM PF DN 25

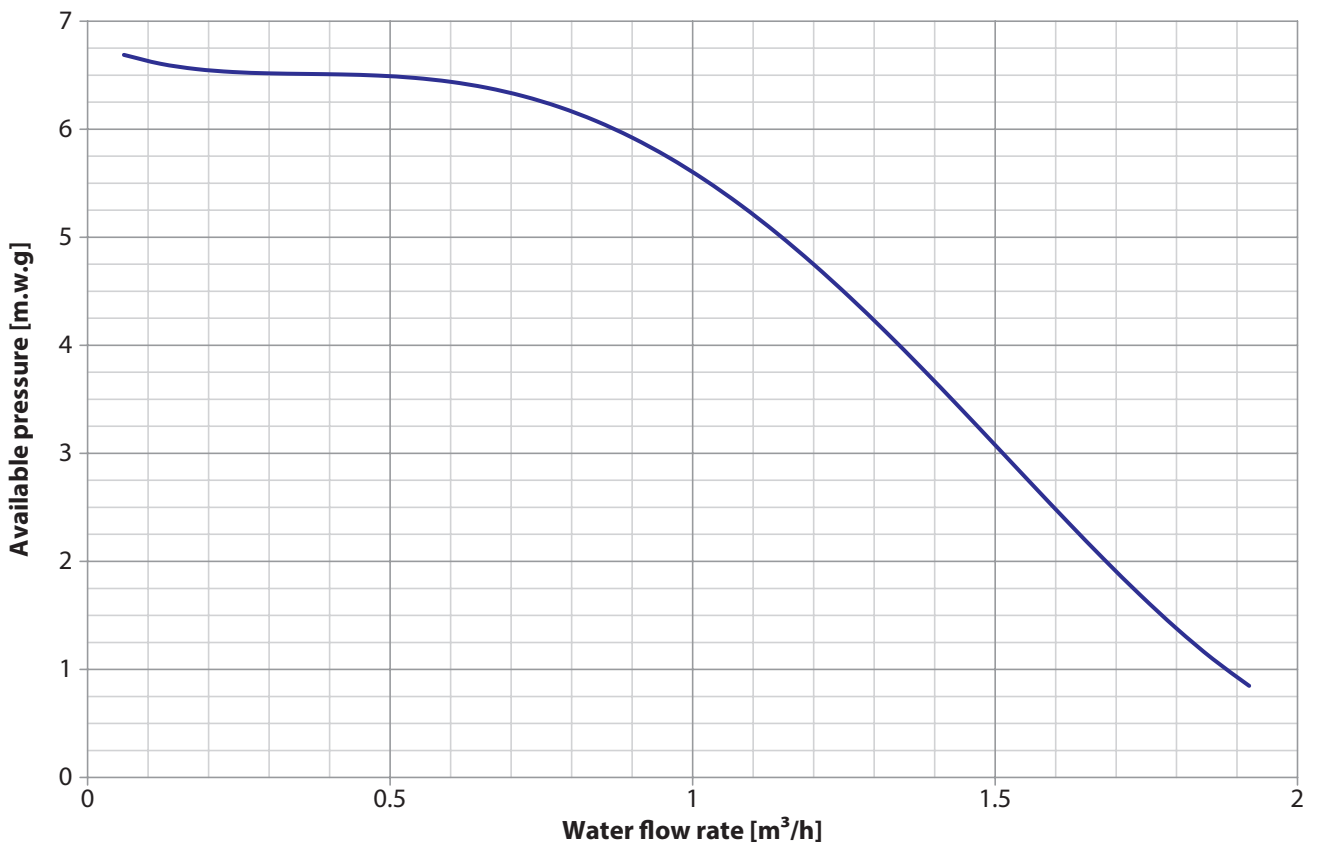



3-POINT GM DN 25

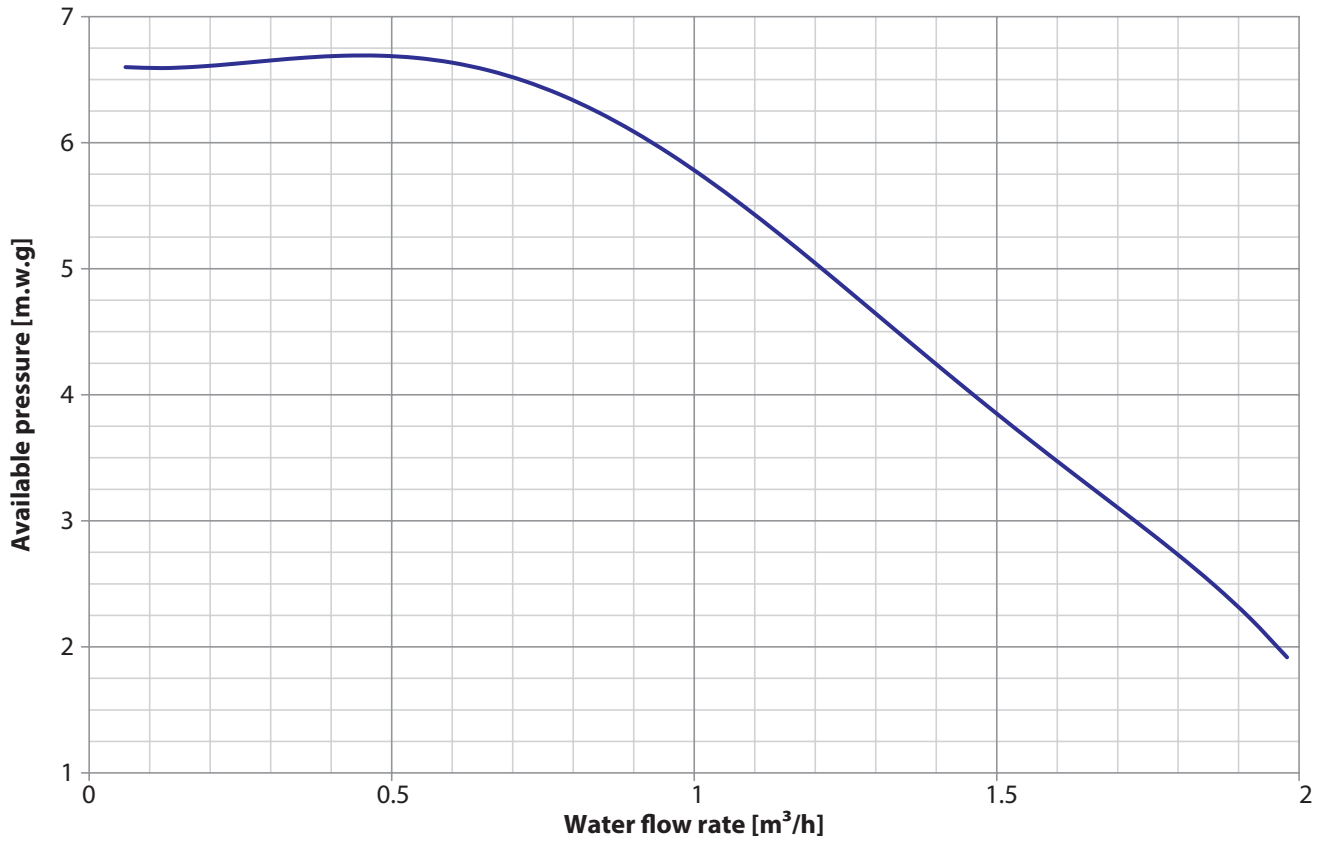

GM VJ / PF-CF DN 25

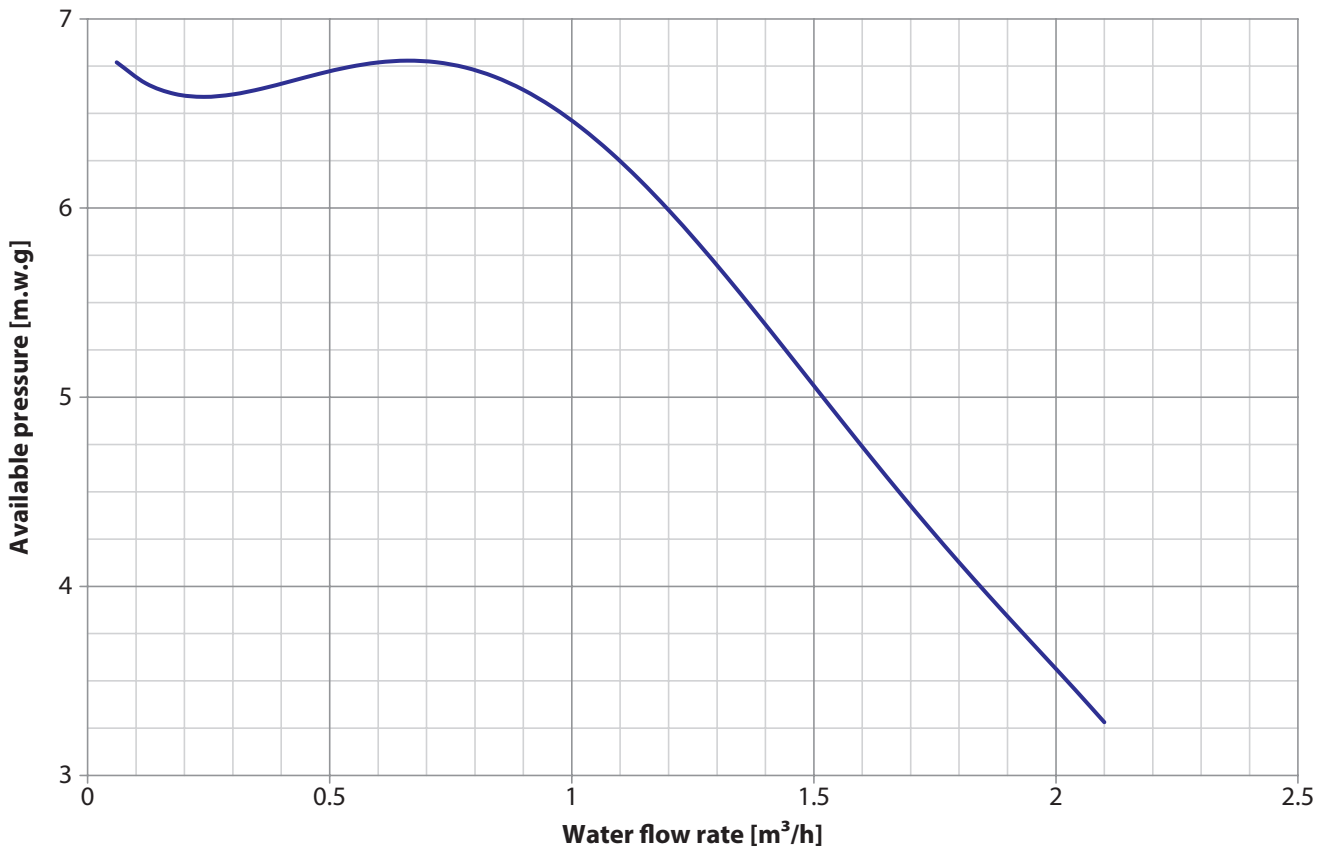



GM PF DN 32

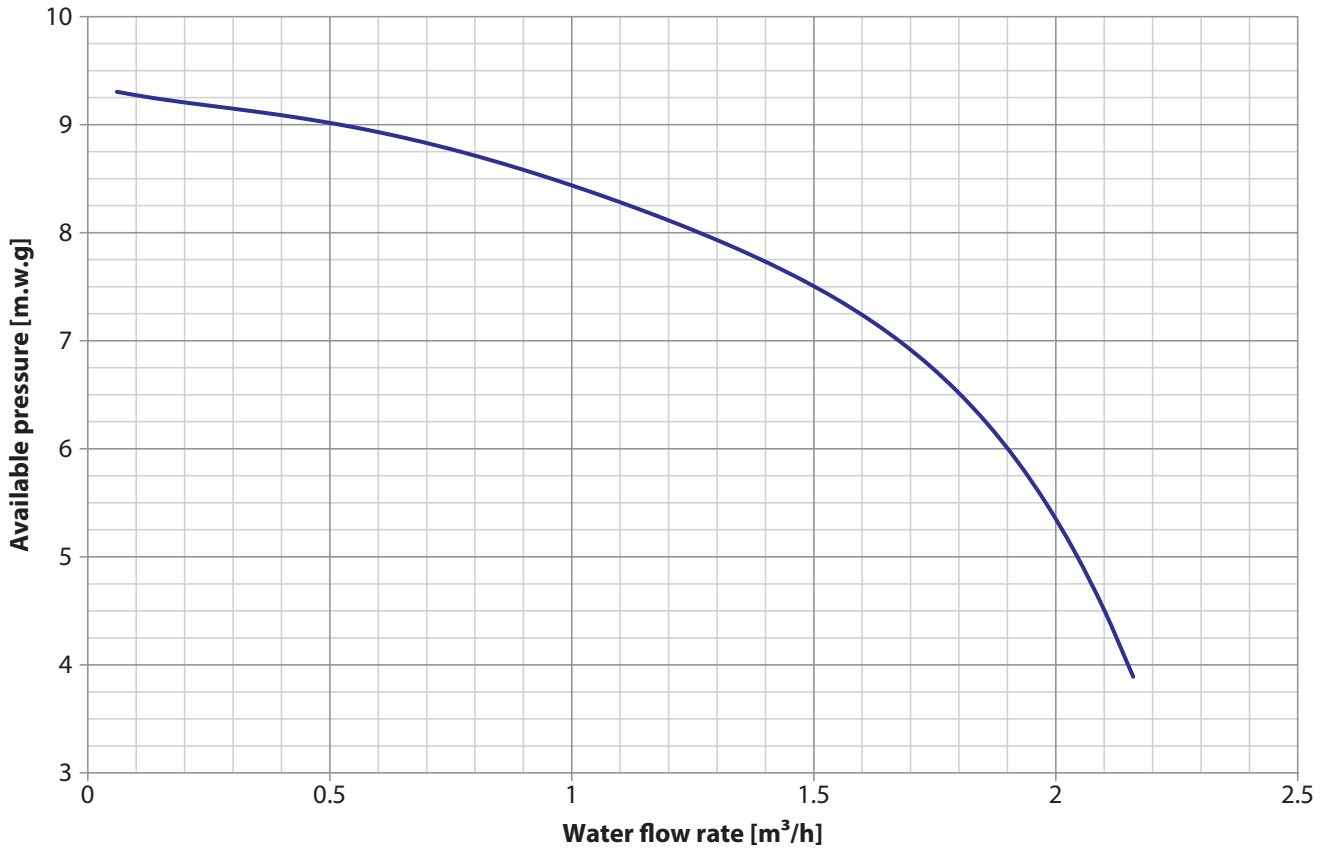

GM VJ / PF-CF DN 32

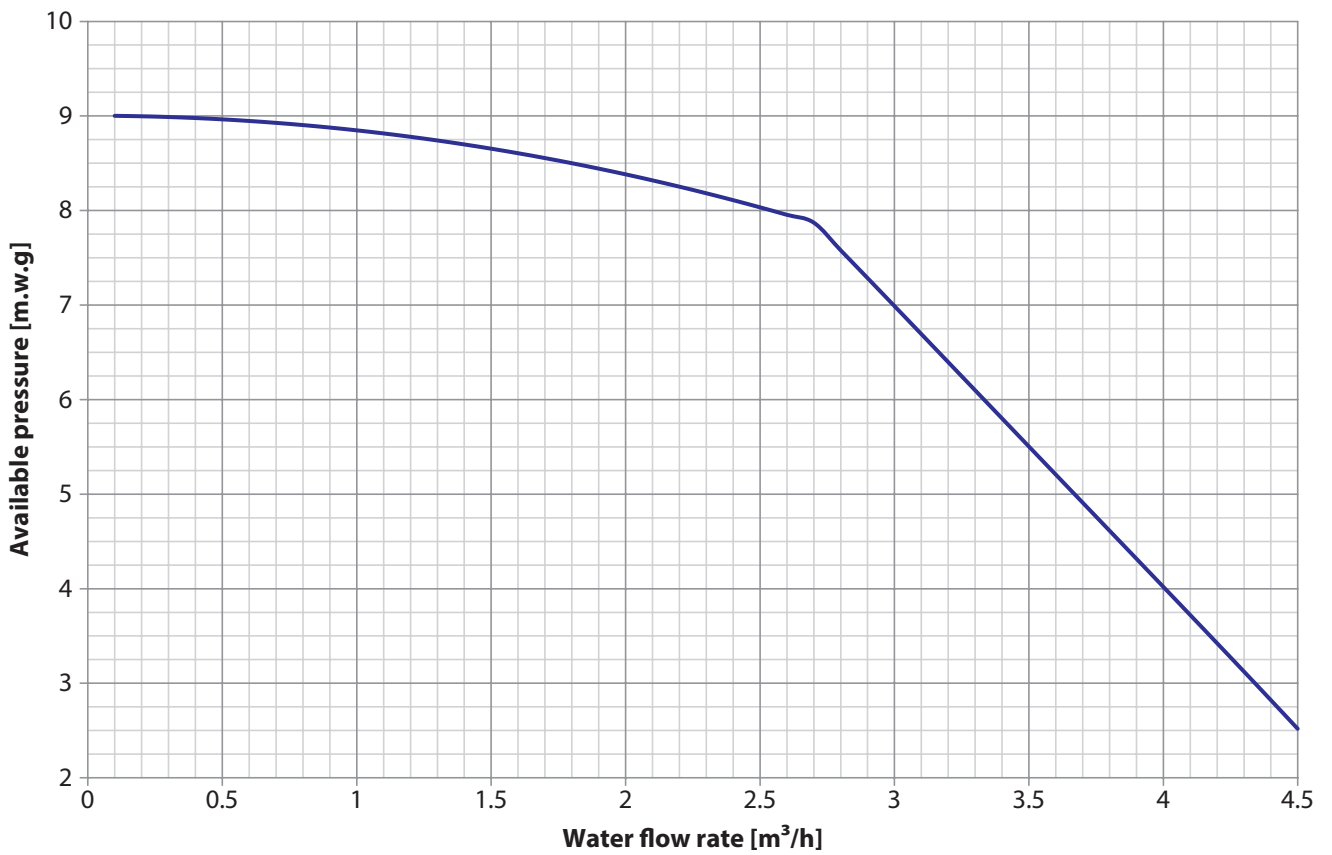

CLICK | SCAN



qr.rdz.it/?qr=P352
FAF0DC00BZ.01
10/2020



RDZ S.p.A.

🏠 V.le Trento, 101 - 33077 SACILE (PN) - Italy

☎ Tel. +39 0434.787511 📠 Fax +39 0434.787522

✉ info@rdz.it 🌐 www.rdz.it

**COMPANY WITH
QUALITY SYSTEM
CERTIFIED BY DNV GL
= ISO 9001 =**